

Specifications

S68-LC (Standard Inertia)

Dyna Pro[®]

Dynamometers

Redefining Industry Standards

Dynamometers & Accessories (EU Specification)

Dyna Pro S68-LC Chassis Dynamometer with Eddy-Brake



Designed and Manufactured in the UK

General Technical Specifications

Maximum Power (Dynamic)	600 hp	Vehicle Type	Bike
Maximum Power (Static)	270 hp	Loading Type	Inertia & Eddy Brake
Maximum Torque	500 ft/lb		
Maximum Rear Wheel Speed	200 mph	Speed Encoder System	Digital
Modeled Mass	158 Kg (348 lbs)	Ignition Pick-up	Digital (Intelligent Pri, & Sec)
Drive Roller Diameter	45.3 cm (17.83")	Data Acquisition System	Digital High Speed USB
Drive Roller Width	45.0 cm (17.71")	Length (Without Ramp)	270.4 cm (106.46")
Drive Roller Inertia	8.0 Kg/m ²	Width	179.8 cm (70.79")
Drive Roller Surface	Knurled (Anti-Corrosion Zinc)	Height (Deck)	44.9 cm (17.68")
Maximum Bike Length	239.6 cm (94.33")	Height (Overall)	88.4 cm (34.80")
Minimum Bike Length	120.6 cm (47.48")	Weight (Un-Crated)	950 Kg (2090 lbs) (Approx.)
Timing Accuracy	50 nano seconds		
Speed Accuracy	0.01 mph	Supply Voltage	190 - 240 Volts ac 50/60 Hz
RPM Accuracy	0.1 rpm	Maximum Supply Current	32 Amps
Calibration	Calibrated/Check Weights	Air Consumption	<1 CFM (120 psi Max)

Standard Hardware Features

- Eddy Brake with Torque Monitor fitted as standard.
- Eddy brake system fully Closed-Loop with Infrared temperature compensation.
- Fast Dynamic Load Control of Eddy Brake (No user PID control, Self learning)
- Calibration Check Weight and Arm.
- Dyna Run V3 Advanced Windows Software (Software Upgrades Free for life).
- Dynamometer to PC USB Link
- Multi Function Remote Hand Controller.
- Intelligent Ignition Pick-up™ system fitted as standard. (Primary and Secondary)
- Starter System fitted as standard (Also used to calibrate Dynamometer).
- Air Brake System (With emergency lock-down in the event of power failure.)
- 12 Auxiliary 0-5 Volt Data Acquisition Inputs, for connection to additional sensors.
- Machine Construction from 3, 5 & 10mm Precision Laser Cut steel, powder coated finish, Blue & Yellow.
- Designed and Manufactured in the UK
- 1 Day Training (at Dyna Pro Works)
- 2 Year replacement parts warranty.(excluding consumables)

Optional Accessories

- Twin Cooling Fans System (High Speed, High Pressure - Operated from Hand Control Pendant). ***
- Wideband Air Fuel System. (Single Channel, Double Channel and Quad channel). ***
- Weather Station (Temperature, Humidity, Pressure & Relative Air Density). ***
- Gas assisted Loading Ramp. ***
- Keyboard Monitor Shelf. ***
- 4 Channel Type K Thermocouple Unit.
- Ram Air simulation System (Calibrated to road speed).
- Infrared Temperature monitor (up to 500°C).
- Exhaust Extraction Kit.
- Exhaust Arms.
- Carbide Drive Roller Coating.

Dimensions & Clearance

*Dynamometer show with optional Gas Ramp Fitted

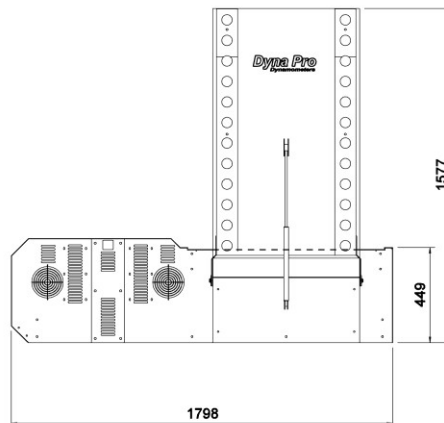
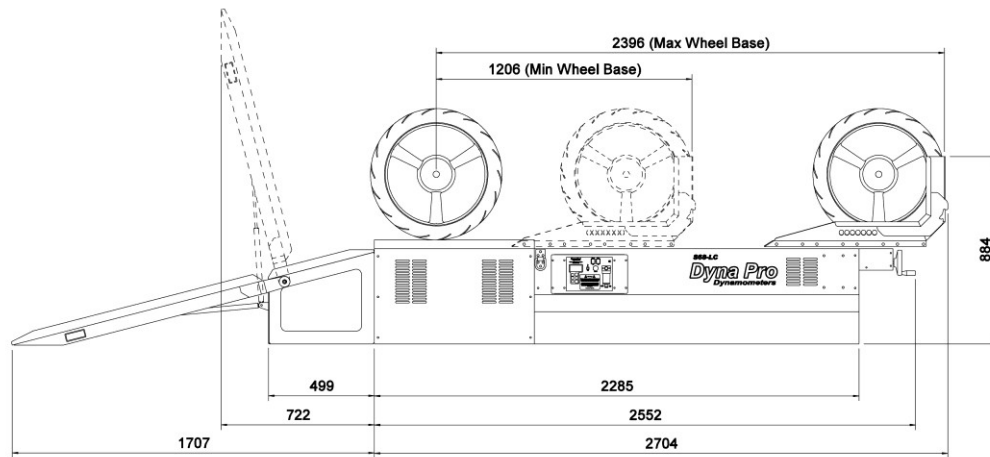
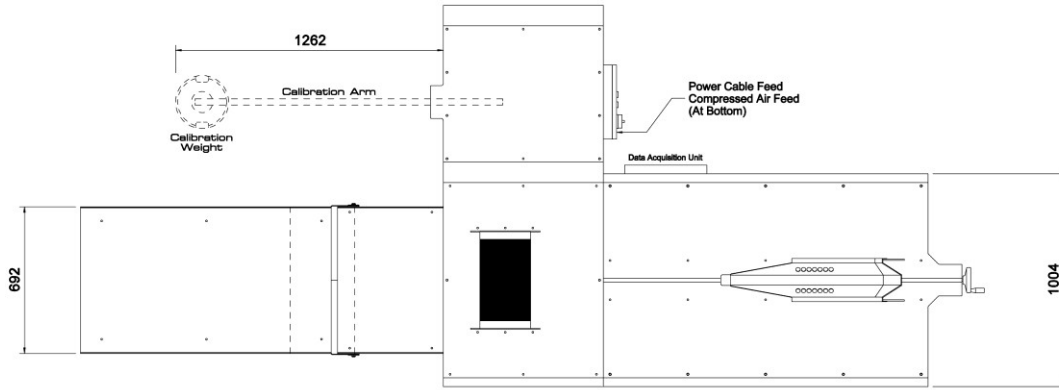

Electrical

190-240V ac Single Phase
 Max Current 32 Amps
 Fuse at 32 Amps
 6mm² Minimum Cable size recommended

Air Supply

90 to 120 PSI
 Smaller than 1CFM

Items shown **** above come as standard with the show package deal.

Specifications are correct at time of print, manufacturer's specification subject to change without notice.

Copyright © Dyna Pro Dynamometers Limited 2011

Dyna Pro Dynamometers Ltd

Unit 18, Sherrington Way, Lister Road Industrial Estate, Basingstoke, Hampshire, UK. RG22 4DQ

Tel (UK): 08000 4321 68

Tel (Int.): +44 (0)1256 363063

www.dynapro.co.uk

E-mail: info@dynapro.co.uk